

Part No:	GH-15502-B
Holding Capacity:	550 Kg
Bar Opens:	100°/140°
Handle Opens:	50°/60°
Weight:	2.6 Kg
Spindle Supplied:	SA-161520
Flanged Washers:	FW-120

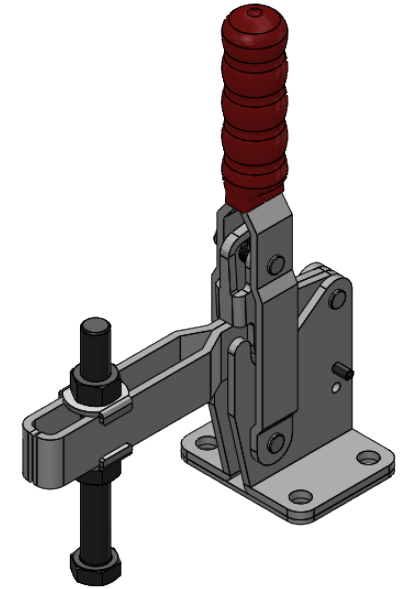
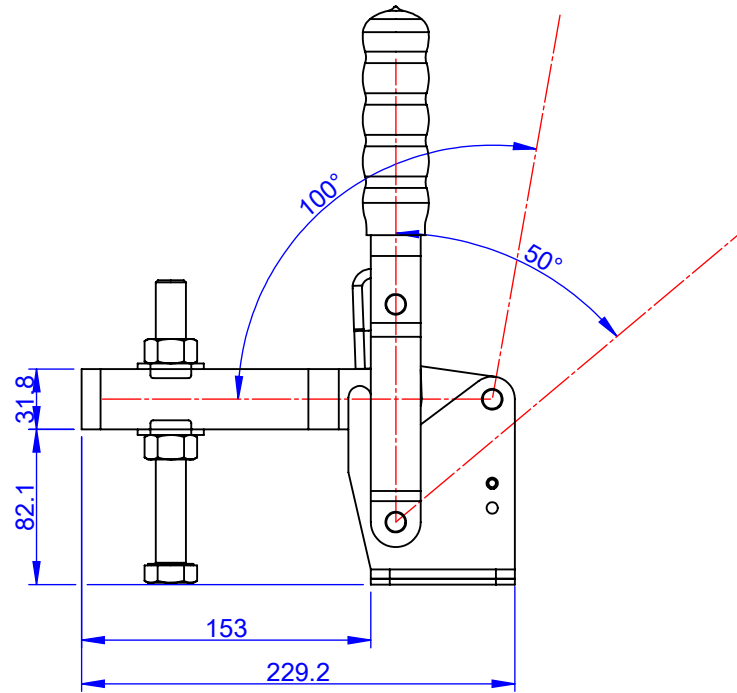
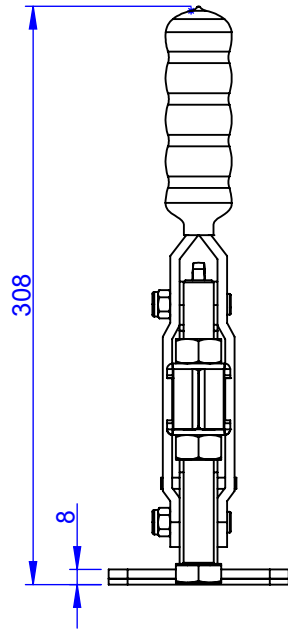
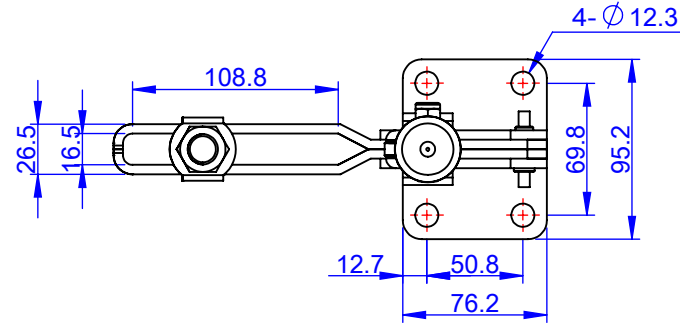

Drawing Scale:1:4
Unit:mm

 **Good Hand Enterprise Co., Ltd**

TITLE:	
DWG NO.	GH-15502-B
	A4