

# GH-5 series

**Toggle pliers have the advantage of a pivoting jaw mechanism to allow a deep throat depth to open and close easily when clamping awkward profiles such as steel angle section.**

**The jaw spindle can be pre-set to achieve the optimum clamping distance and pressure which is most useful for repetitious clamping applications.**

## **Features include:**

- Heavy duty forged steel jaws and handles to achieve high clamping forces without flexing.
- All pliers and fabricating clamps are zinc plated finish to resist corrosion and have profiled handles for improved operator comfort.
- Models GH-50380 & GH-50450 & GH-50480 are manufactured with an integral central release trigger to facilitate quick release with minimum effort.
- Most spindles are supplied with a copper plated surface finish to resist weld spatter.
- Pivot points are fitted with hardened steel or stainless steel rivets to maintain accuracy and provide a long service life.

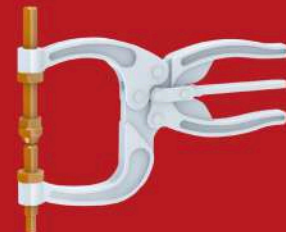

**GH 50350**

- Holding Capacity 99Kg
- Weight 0.19Kg
- Spindle Supplied SA-14112



GH-50350

Unit:mm

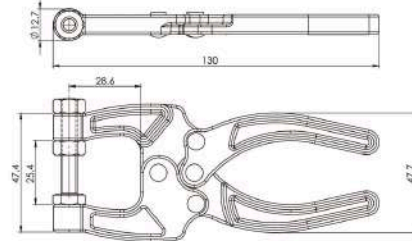

**GH 50450**

- Holding Capacity 318Kg
- Weight 0.74Kg
- Spindle Supplied SF-38300 & SA-38300

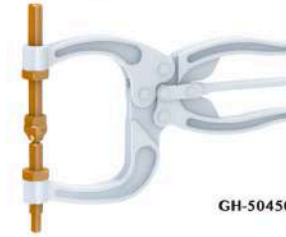

GH-50450

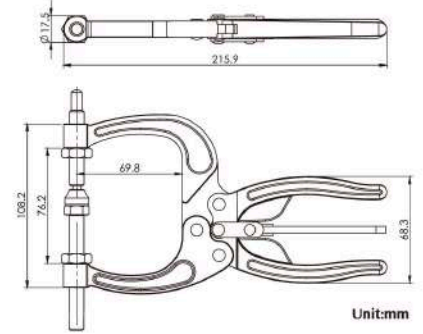

Unit:mm

**GH 50360**

- Holding Capacity 159Kg
- Weight 0.29Kg
- Spindle Supplied SA-56200



GH-50360

Unit:mm

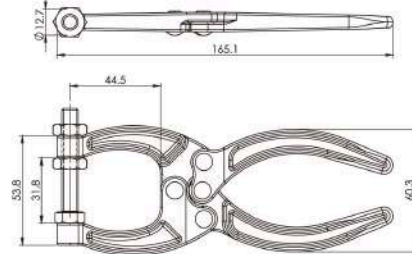

**GH 50480**

- Holding Capacity 500Kg
- Weight 0.61Kg



GH-50480

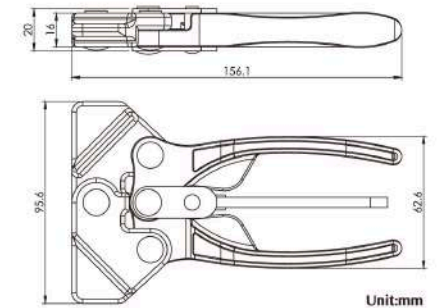

Unit:mm

**GH 50380**

- Holding Capacity 318Kg
- Weight 0.63Kg
- Spindle Supplied SF-38300



GH-50380

Unit:mm

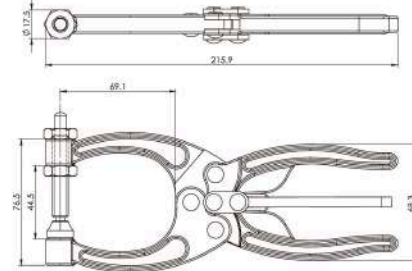

**GH 51105**

- Holding Capacity 102Kg
- Weight 0.18Kg



GH-51105

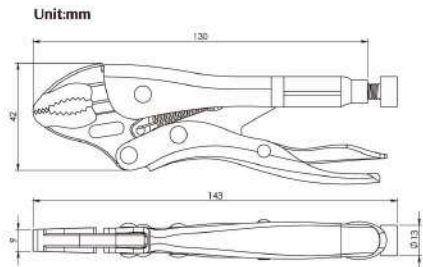

Unit:mm

**GH 50385**

- Holding Capacity 820Kg
- Weight 0.75Kg
- Spindle Supplied SA-38114



GH-50385

Unit:mm

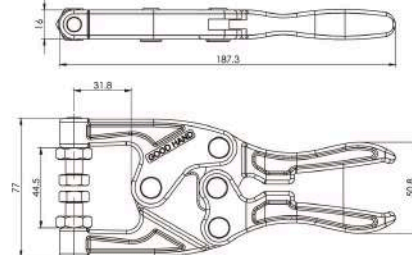

**GH 51106**

- Holding Capacity 102Kg
- Weight 0.19Kg



GH-51106

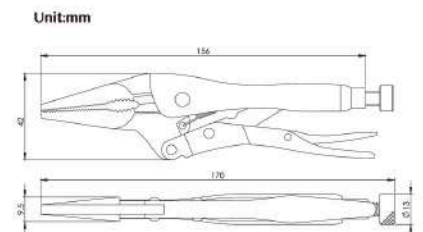

Unit:mm

**GH 51150**

● Holding Capacity | 350Kg  
● Weight | 0.34Kg



GH-51150

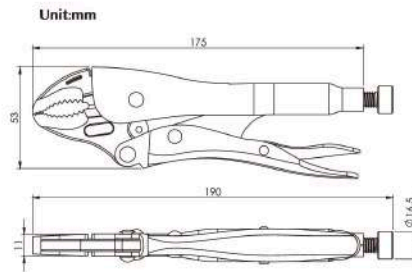

**GH 51111**

● Holding Capacity | 350Kg  
● Weight | 0.85Kg



GH-51111

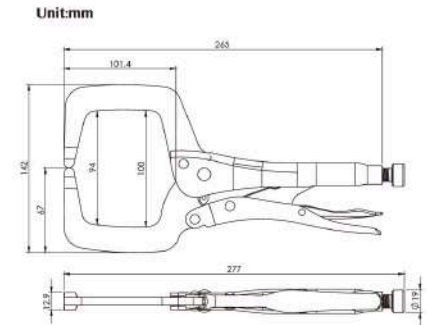

**GH 51152**

● Holding Capacity | 400Kg  
● Weight | 0.52Kg



GH-51152

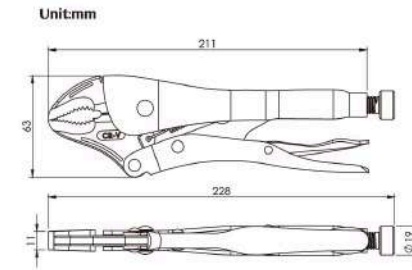

**GH 511SP**

● Holding Capacity | 350Kg  
● Weight | 0.85Kg



GH-511SP

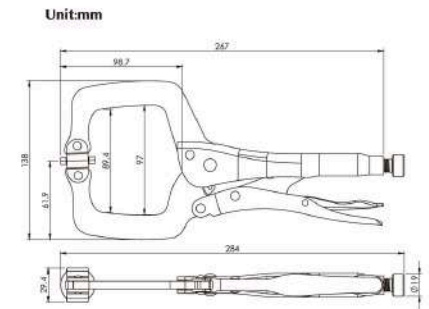

**GH 51151**

● Holding Capacity | 580Kg  
● Weight | 0.52Kg



GH-51151

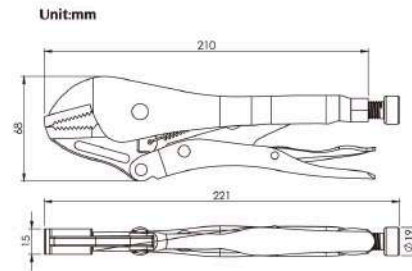

**GH 51000**

● Holding Capacity | 200Kg  
● Weight | 0.27Kg  
● Spindle Supplied | SA-56112



GH-51000

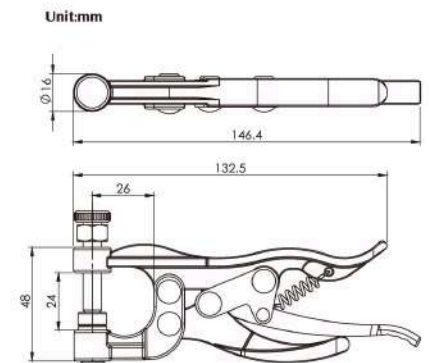

**GH 51100**

● Holding Capacity | 350Kg  
● Weight | 0.85Kg



GH-51100

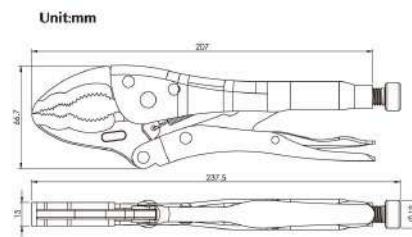

**GH 51010**

- Holding Capacity | 250Kg
- Weight | 0.48Kg
- Spindle Supplied | SA-56112



**GH-51010**

Unit:mm

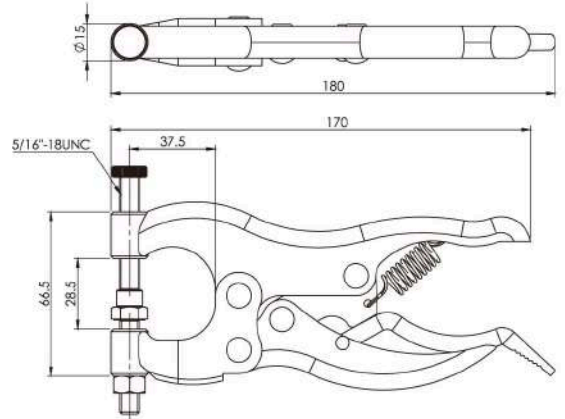

**GH 51020**

- Holding Capacity | 300Kg
- Weight | 0.66Kg



**GH-51020**

Unit:mm

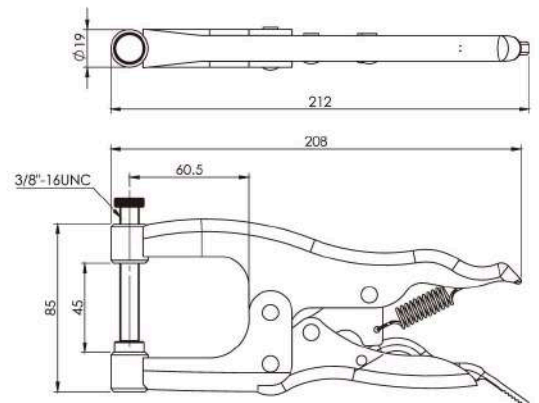

**GH 51030**

- Holding Capacity | 260Kg
- Weight | 0.86Kg



**GH-51030**

Unit:mm

